

MC74HC4066A

Quad Analog Switch/ Multiplexer/Demultiplexer

High-Performance Silicon-Gate CMOS

The MC74HC4066A utilizes silicon-gate CMOS technology to achieve fast propagation delays, low ON resistances, and low OFF-channel leakage current. This bilateral switch/multiplexer/demultiplexer controls analog and digital voltages that may vary across the full power-supply range (from V_{CC} to GND).

The HC4066A is identical in pinout to the metal-gate CMOS MC14016 and MC14066. Each device has four independent switches. The device has been designed so the ON resistances (R_{ON}) are more linear over input voltage than R_{ON} of metal-gate CMOS analog switches.

The ON/OFF control inputs are compatible with standard CMOS outputs; with pullup resistors, they are compatible with LSTTL outputs. For analog switches with voltage-level translators, see the HC4316A.

Features

- Fast Switching and Propagation Speeds
- High ON/OFF Output Voltage Ratio
- Low Crosstalk Between Switches
- Diode Protection on All Inputs/Outputs
- Wide Power-Supply Voltage Range ($V_{CC} - GND$) = 2.0 to 12.0 V
- Analog Input Voltage Range ($V_{CC} - GND$) = 2.0 to 12.0 V
- Improved Linearity and Lower ON Resistance over Input Voltage than the MC14016 or MC14066
- Low Noise
- Chip Complexity: 44 FETs or 11 Equivalent Gates
- Pb-Free Packages are Available



ON Semiconductor®

<http://onsemi.com>

MARKING DIAGRAMS

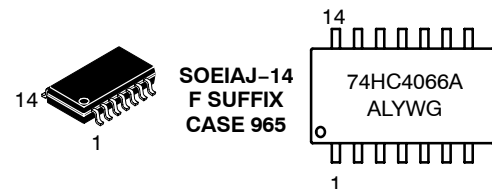
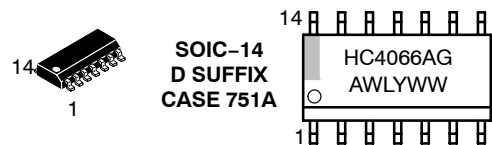
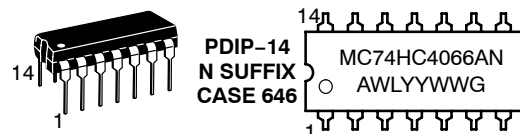

A = Assembly Location

L, WL = Wafer Lot

Y, YY = Year

W, WW = Work Week

G or ■ = Pb-Free Package

(Note: Microdot may be in either location)

ORDERING INFORMATION

See detailed ordering and shipping information in the package dimensions section on page 2 of this data sheet.

MC74HC4066A

PIN ASSIGNMENT

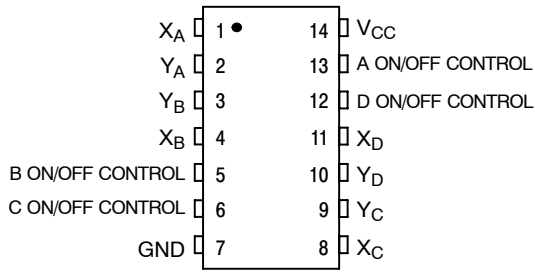

FUNCTION TABLE

On/Off Control Input	State of Analog Switch
L	Off
H	On

LOGIC DIAGRAM

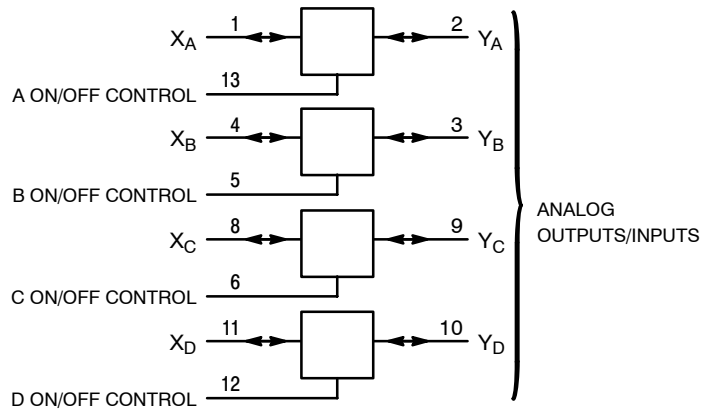

ANALOG INPUTS/OUTPUTS = X_A, X_B, X_C, X_D
 PIN 14 = V_{CC}
 PIN 7 = GND

ORDERING INFORMATION

Device	Package	Shipping [†]
MC74HC4066AN	PDIP-14	25 Units / Rail
MC74HC4066ANG	PDIP-14 (Pb-Free)	
MC74HC4066AD	SOIC-14	55 Units / Rail
MC74HC4066ADG	SOIC-14 (Pb-Free)	
MC74HC4066ADR2	SOIC-14	2500 / Tape & Reel
MC74HC4066ADR2G	SOIC-14 (Pb-Free)	
MC74HC4066ADTR2	TSSOP-14*	
MC74HC4066ADTR2G	TSSOP-14*	
MC74HC4066AFEL	SOEIAJ-14	2000 / Tape & Reel
MC74HC4066AFELG	SOEIAJ-14 (Pb-Free)	

[†]For information on tape and reel specifications, including part orientation and tape sizes, please refer to our Tape and Reel Packaging Specifications Brochure, BRD8011/D.

*This package is inherently Pb-Free.

MC74HC4066A

MAXIMUM RATINGS

Symbol	Parameter	Value	Unit
V _{CC}	Positive DC Supply Voltage (Referenced to GND)	- 0.5 to + 14.0	V
V _{IS}	Analog Input Voltage (Referenced to GND)	- 0.5 to V _{CC} + 0.5	V
V _{in}	Digital Input Voltage (Referenced to GND)	- 0.5 to V _{CC} + 0.5	V
I	DC Current Into or Out of Any Pin	± 25	mA
P _D	Power Dissipation in Still Air, Plastic DIP† EIAJ/SOIC Package† TSSOP Package†	750	mW
		500	
		450	
T _{stg}	Storage Temperature	- 65 to + 150	°C
T _L	Lead Temperature, 1 mm from Case for 10 Seconds (Plastic DIP, SOIC or TSSOP Package)	260	°C

This device contains protection circuitry to guard against damage due to high static voltages or electric fields. However, precautions must be taken to avoid applications of any voltage higher than maximum rated voltages to this high-impedance circuit. For proper operation, V_{in} and V_{out} should be constrained to the range GND ≤ (V_{in} or V_{out}) ≤ V_{CC}. Unused inputs must always be tied to an appropriate logic voltage level (e.g., either GND or V_{CC}). Unused outputs must be left open. I/O pins must be connected to a properly terminated line or bus.

Stresses exceeding Maximum Ratings may damage the device. Maximum Ratings are stress ratings only. Functional operation above the Recommended Operating Conditions is not implied. Extended exposure to stresses above the Recommended Operating Conditions may affect device reliability.

†Derating - Plastic DIP: - 10 mW/°C from 65° to 125°C
EIAJ/SOIC Package: - 7 mW/°C from 65° to 125°C
TSSOP Package: - 6.1 mW/°C from 65° to 125°C

For high frequency or heavy load considerations, see the ON Semiconductor High-Speed CMOS Data Book (DL129/D).

RECOMMENDED OPERATING CONDITIONS

Symbol	Parameter	Min	Max	Unit	
V _{CC}	Positive DC Supply Voltage (Referenced to GND)	2.0	12.0	V	
V _{IS}	Analog Input Voltage (Referenced to GND)	GND	V _{CC}	V	
V _{in}	Digital Input Voltage (Referenced to GND)	GND	V _{CC}	V	
V _{IO} *	Static or Dynamic Voltage Across Switch	-	1.2	V	
T _A	Operating Temperature, All Package Types	-55	+ 125	°C	
t _r , t _f	Input Rise and Fall Time, ON/OFF Control Inputs (Figure 10)	V _{CC} = 2.0 V	0	1000	ns
		V _{CC} = 3.0 V	0	600	
		V _{CC} = 4.5 V	0	500	
		V _{CC} = 9.0 V	0	400	
		V _{CC} = 12.0 V	0	250	

*For voltage drops across the switch greater than 1.2 V (switch on), excessive V_{CC} current may be drawn; i.e., the current out of the switch may contain both V_{CC} and switch input components. The reliability of the device will be unaffected unless the Maximum Ratings are exceeded.

DC ELECTRICAL CHARACTERISTIC Digital Section (Voltages Referenced to GND)

Symbol	Parameter	Test Conditions	V _{CC} V	Guaranteed Limit			Unit
				- 55 to 25°C	≤ 85°C	≤ 125°C	
V _{IH}	Minimum High-Level Voltage ON/OFF Control Inputs	R _{on} = Per Spec	2.0	1.5	1.5	1.5	V
			3.0	2.1	2.1	2.1	
			4.5	3.15	3.15	3.15	
			9.0	6.3	6.3	6.3	
			12.0	8.4	8.4	8.4	
V _{IL}	Maximum Low-Level Voltage ON/OFF Control Inputs	R _{on} = Per Spec	2.0	0.5	0.5	0.5	V
			3.0	0.9	0.9	0.9	
			4.5	1.35	1.35	1.35	
			9.0	2.7	2.7	2.7	
			12.0	3.6	3.6	3.6	
I _{in}	Maximum Input Leakage Current ON/OFF Control Inputs	V _{in} = V _{CC} or GND	12.0	± 0.1	± 1.0	± 1.0	µA
I _{CC}	Maximum Quiescent Supply Current (per Package)	V _{in} = V _{CC} or GND V _{IO} = 0 V	6.0	2	20	40	µA
			12.0	4	40	160	

NOTE: Information on typical parametric values can be found in the ON Semiconductor High-Speed CMOS Data Book (DL129/D).

MC74HC4066A

DC ELECTRICAL CHARACTERISTICS Analog Section (Voltages Referenced to GND)

Symbol	Parameter	Test Conditions	V _{CC} V	Guaranteed Limit			Unit
				- 55 to 25°C	≤ 85°C	≤ 125°C	
R _{on}	Maximum "ON" Resistance	V _{in} = V _{IH} V _{IS} = V _{CC} to GND I _S ≤ 2.0 mA (Figures 1, 2)	2.0†	-	-	-	Ω
			3.0†	-	-	-	
			4.5	120	160	200	
			9.0	70	85	100	
			12.0	70	85	100	
		V _{in} = V _{IH} V _{IS} = V _{CC} or GND (Endpoints) I _S ≤ 2.0 mA (Figures 1, 2)	2.0	-	-	-	
			3.0	-	-	-	
			4.5	70	85	120	
			9.0	50	60	80	
			12.0	50	60	80	
ΔR _{on}	Maximum Difference in "ON" Resistance Between Any Two Channels in the Same Package	V _{in} = V _{IH} V _{IS} = 1/2 (V _{CC} - GND) I _S ≤ 2.0 mA	2.0	-	-	-	Ω
			4.5	20	25	30	
			9.0	15	20	25	
			12.0	15	20	25	
I _{off}	Maximum Off-Channel Leakage Current, Any One Channel	V _{in} = V _{IL} V _{IO} = V _{CC} or GND Switch Off (Figure 3)	12.0	0.1	0.5	1.0	μA
I _{on}	Maximum On-Channel Leakage Current, Any One Channel	V _{in} = V _{IH} V _{IS} = V _{CC} or GND (Figure 4)	12.0	0.1	0.5	1.0	μA

†At supply voltage (V_{CC}) approaching 3 V the analog switch-on resistance becomes extremely non-linear. Therefore, for low-voltage operation, it is recommended that these devices only be used to control digital signals.

NOTE: Information on typical parametric values can be found in the ON Semiconductor High-Speed CMOS Data Book (DL129/D).

AC ELECTRICAL CHARACTERISTICS (C_L = 50 pF, ON/OFF Control Inputs: t_r = t_f = 6 ns)

Symbol	Parameter	V _{CC} V	Guaranteed Limit			Unit	
			- 55 to 25°C	≤ 85°C	≤ 125°C		
t _{PLH} , t _{PHL}	Maximum Propagation Delay, Analog Input to Analog Output (Figures 8 and 9)	2.0	40	50	60	ns	
		3.0	30	40	50		
		4.5	10	13	15		
		9.0	10	13	15		
		12.0	10	13	15		
t _{PLZ} , t _{PHZ}	Maximum Propagation Delay, ON/OFF Control to Analog Output (Figures 10 and 11)	2.0	80	90	110	ns	
		3.0	60	70	80		
		4.5	30	38	45		
		9.0	25	28	30		
		12.0	25	28	30		
t _{PZL} , t _{PZH}	Maximum Propagation Delay, ON/OFF Control to Analog Output (Figures 10 and 1 1)	2.0	80	90	100	ns	
		3.0	45	50	60		
		4.5	25	32	37		
		9.0	25	32	37		
		12.0	25	32	37		
C	Maximum Capacitance	ON/OFF Control Input	-	10	10	10	pF
		Control Input = GND	-	35	35	35	
		Analog I/O Feedthrough	-	1.0	1.0	1.0	

NOTES:

- For propagation delays with loads other than 50 pF, see the ON Semiconductor High-Speed CMOS Data Book (DL129/D).
- Information on typical parametric values can be found in the ON Semiconductor High-Speed CMOS Data Book (DL129/D).

C _{PD}	Power Dissipation Capacitance (Per Switch) (Figure 13)*	Typical @ 25°C, V _{CC} = 5.0 V			pF
		15			

* Used to determine the no-load dynamic power consumption: P_D = C_{PD} V_{CC}²f + I_{CC} V_{CC}. For load considerations, see the ON Semiconductor High-Speed CMOS Data Book (DL129/D).

MC74HC4066A

ADDITIONAL APPLICATION CHARACTERISTICS (Voltages Referenced to GND Unless Noted)

Symbol	Parameter	Test Conditions	V _{CC} V	Limit* 25°C 54/74HC	Unit
BW	Maximum On-Channel Bandwidth or Minimum Frequency Response (Figure 5)	f _{in} = 1 MHz Sine Wave Adjust f _{in} Voltage to Obtain 0 dBm at V _{OS} Increase f _{in} Frequency Until dB Meter Reads - 3 dB R _L = 50 Ω, C _L = 10 pF	4.5 9.0 12.0	150 160 160	MHz
-	Off-Channel Feedthrough Isolation (Figure 6)	f _{in} ≡ Sine Wave Adjust f _{in} Voltage to Obtain 0 dBm at V _{IS} f _{in} = 10 kHz, R _L = 600 Ω, C _L = 50 pF f _{in} = 1.0 MHz, R _L = 50 Ω, C _L = 10 pF	4.5 9.0 12.0 4.5 9.0 12.0	- 50 - 50 - 50 - 40 - 40 - 40	dB
-	Feedthrough Noise, Control to Switch (Figure 7)	V _{in} ≤ 1 MHz Square Wave (t _r = t _f = 6 ns) Adjust R _L at Setup so that I _S = 0 A R _L = 600 Ω, C _L = 50 pF R _L = 10 kΩ, C _L = 10 pF	4.5 9.0 12.0 4.5 9.0 12.0	60 130 200 30 65 100	mV _{PP}
-	Crosstalk Between Any Two Switches (Figure 12)	f _{in} ≡ Sine Wave Adjust f _{in} Voltage to Obtain 0 dBm at V _{IS} f _{in} = 10 kHz, R _L = 600 Ω, C _L = 50 pF f _{in} = 1.0 MHz, R _L = 50 Ω, C _L = 10 pF	4.5 9.0 12.0 4.5 9.0 12.0	- 70 - 70 - 70 - 80 - 80 - 80	dB
THD	Total Harmonic Distortion (Figure 14)	f _{in} = 1 kHz, R _L = 10 kΩ, C _L = 50 pF THD = THD _{Measured} - THD _{Source} V _{IS} = 4.0 V _{PP} sine wave V _{IS} = 8.0 V _{PP} sine wave V _{IS} = 11.0 V _{PP} sine wave	4.5 9.0 12.0	0.10 0.06 0.04	%

*Guaranteed limits not tested. Determined by design and verified by qualification.

MC74HC4066A

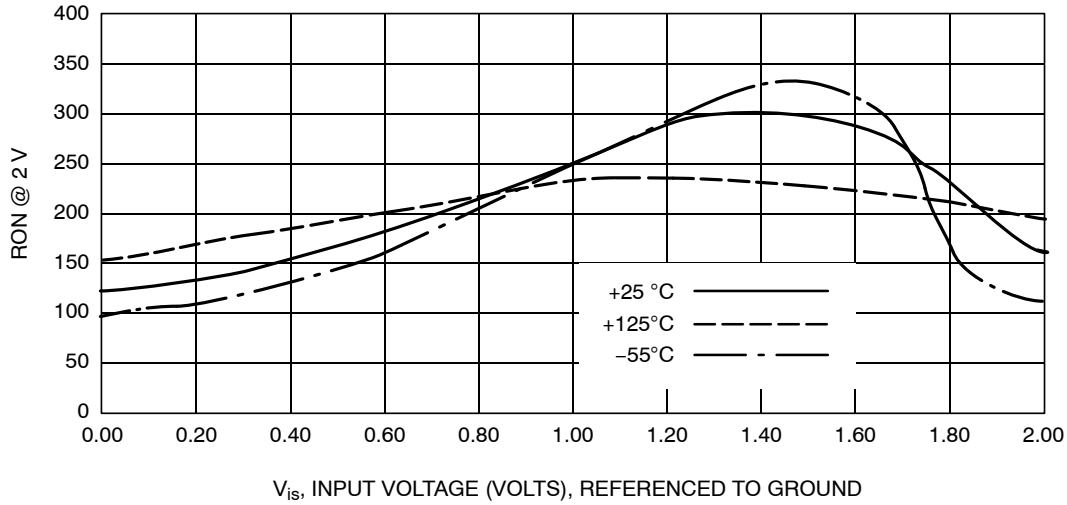

Figure 1a. Typical On Resistance, V_{CC} = 2.0 V

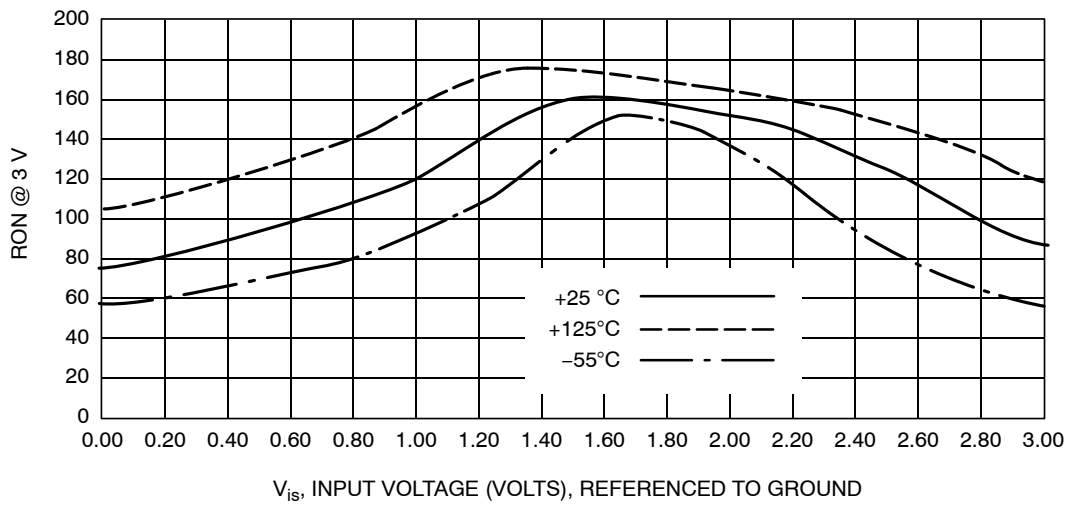

Figure 1b. Typical On Resistance, V_{CC} = 3.0 V

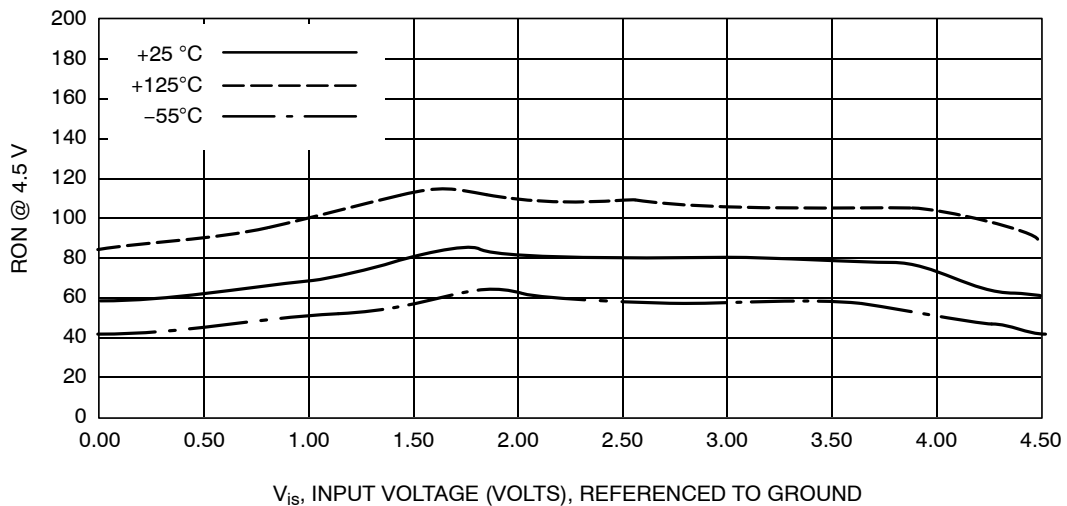
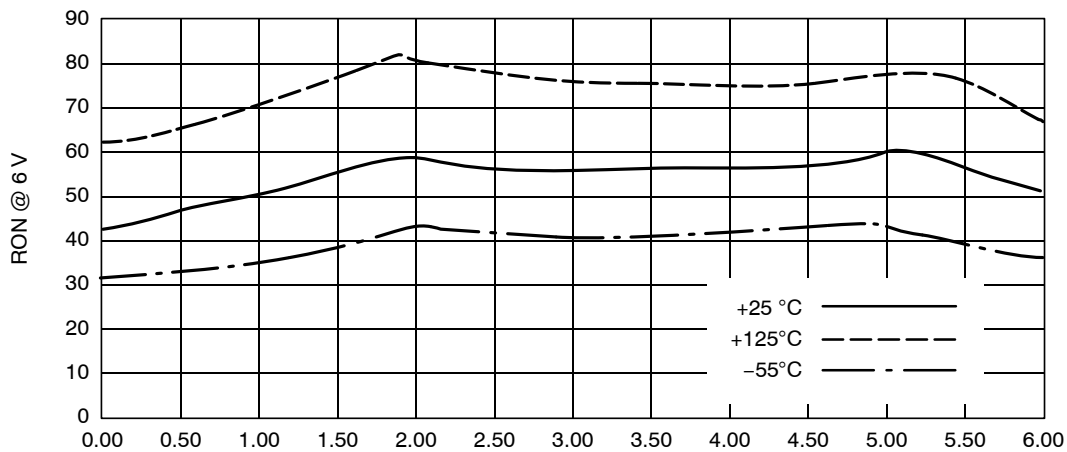

Figure 1c. Typical On Resistance, V_{CC} = 4.5 V

MC74HC4066A



V_{IS}, INPUT VOLTAGE (VOLTS), REFERENCED TO GROUND

Figure 1d. Typical On Resistance, V_{CC} = 6.0 V

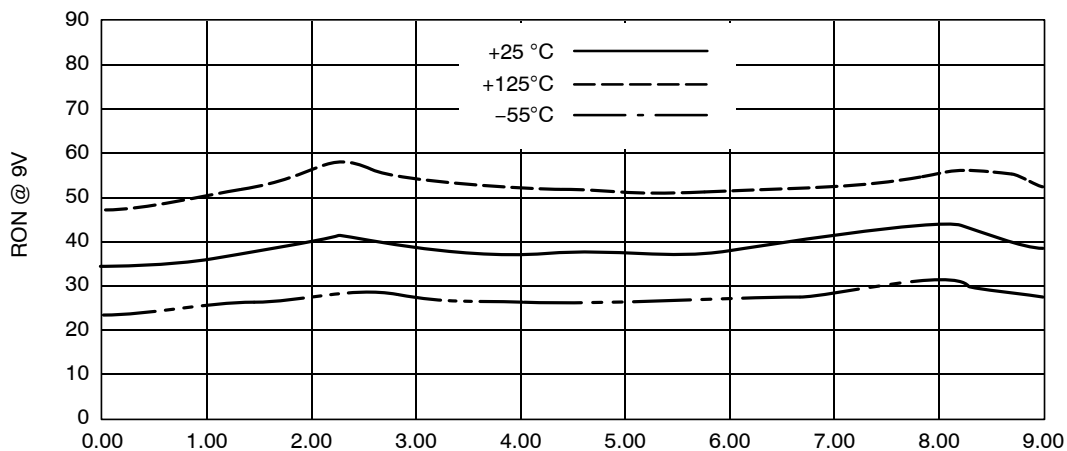

V_{IS}, INPUT VOLTAGE (VOLTS), REFERENCED TO GROUND

Figure 1e. Typical On Resistance, V_{CC} = 9.0 V

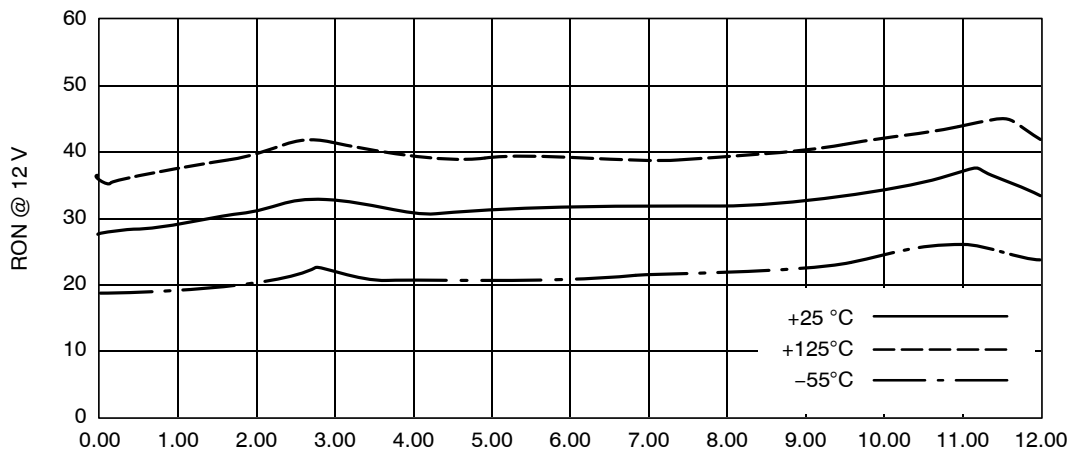

V_{IS}, INPUT VOLTAGE (VOLTS), REFERENCED TO GROUND

Figure 1f. Typical On Resistance, V_{CC} = 12.0 V

MC74HC4066A

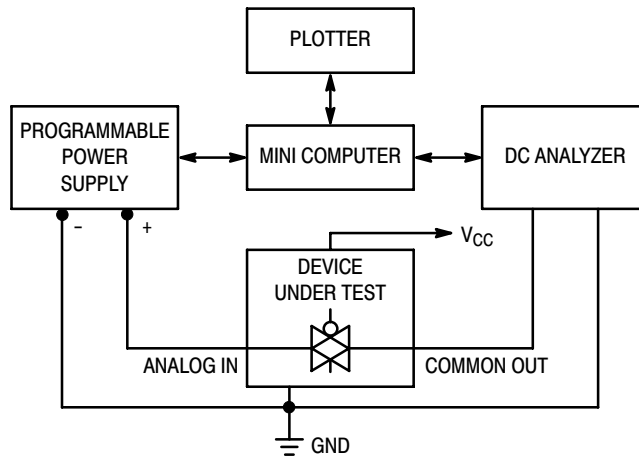

Figure 2. On Resistance Test Set-Up

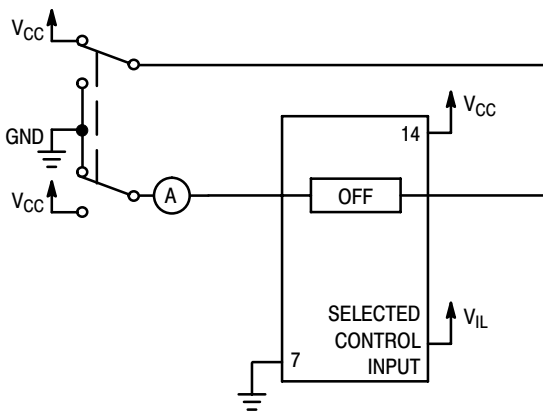

Figure 3. Maximum Off Channel Leakage Current, Any One Channel, Test Set-Up

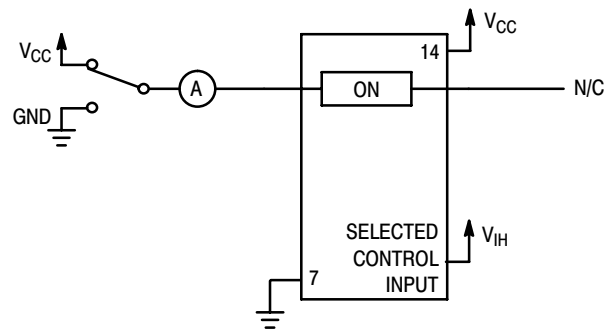
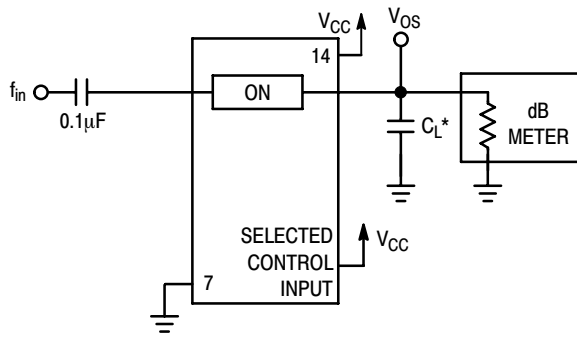
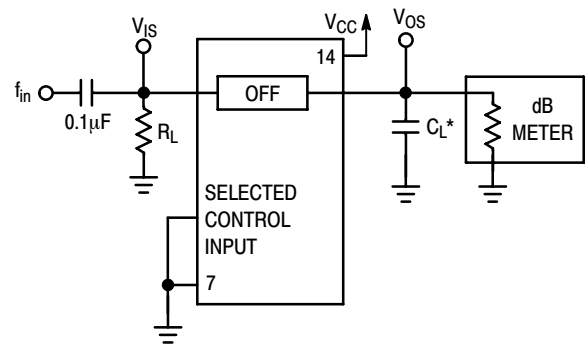

Figure 4. Maximum On Channel Leakage Current, Test Set-Up



*Includes all probe and jig capacitance.

Figure 5. Maximum On-Channel Bandwidth Test Set-Up



*Includes all probe and jig capacitance.

Figure 6. Off-Channel Feedthrough Isolation, Test Set-Up

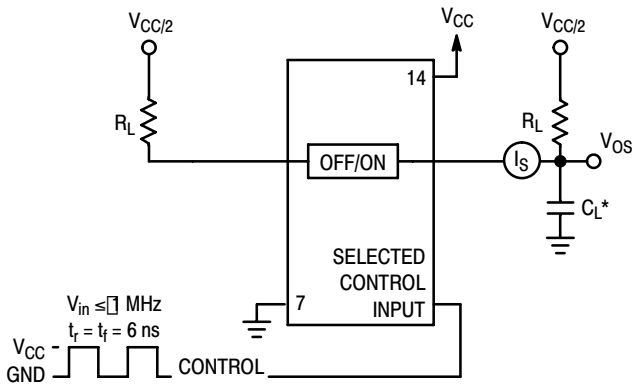

*Includes all probe and jig capacitance.

Figure 7. Feedthrough Noise, ON/OFF Control to Analog Out, Test Set-Up

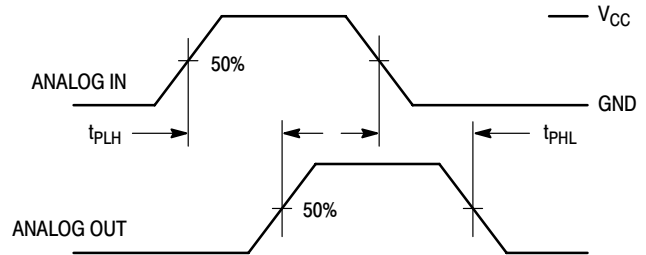
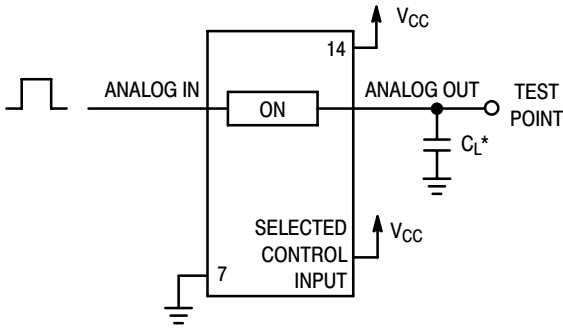

Figure 8. Propagation Delays, Analog In to Analog Out

MC74HC4066A



*Includes all probe and jig capacitance.

Figure 9. Propagation Delay Test Set-Up

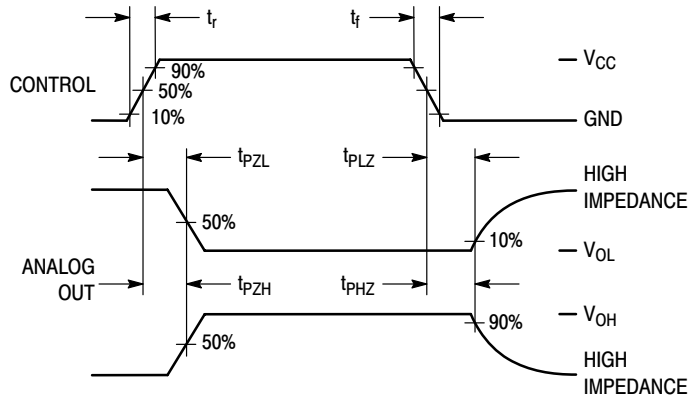
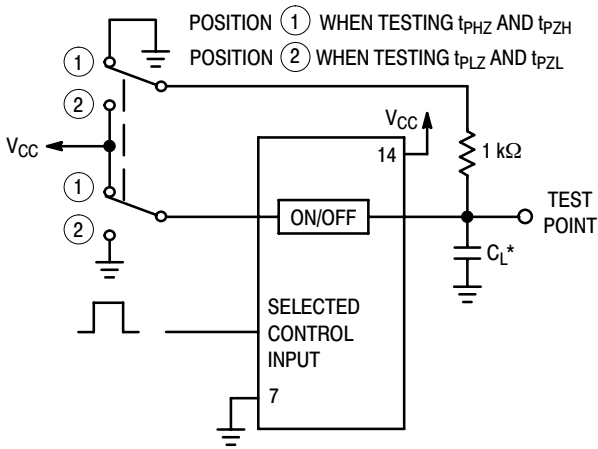
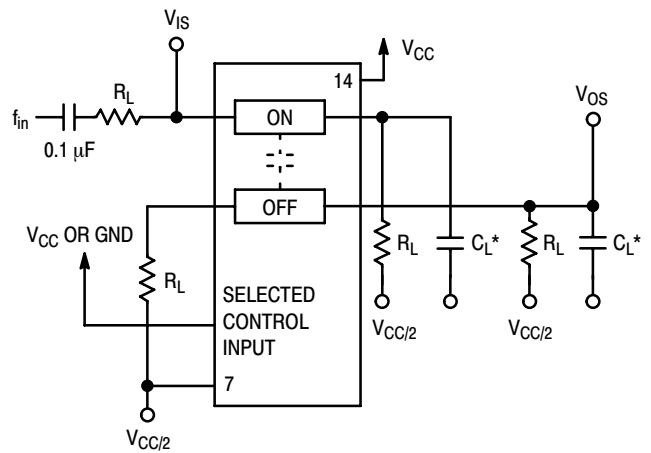

Figure 10. Propagation Delay, ON/OFF Control to Analog Out



*Includes all probe and jig capacitance.

Figure 11. Propagation Delay Test Set-Up



*Includes all probe and jig capacitance.

Figure 12. Crosstalk Between Any Two Switches, Test Set-Up

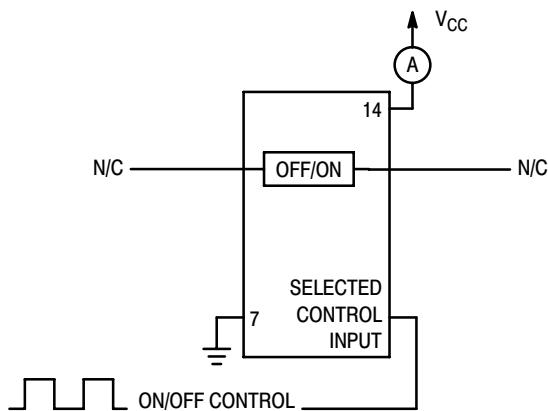
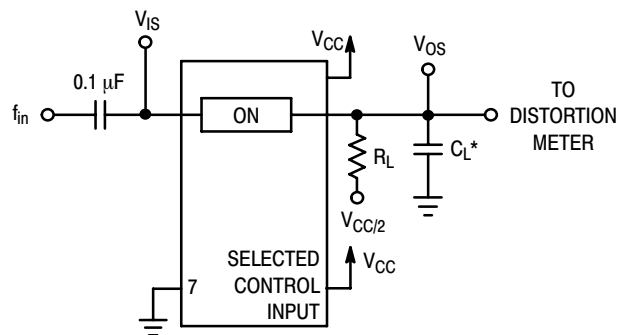

Figure 13. Power Dissipation Capacitance Test Set-Up



*Includes all probe and jig capacitance.

Figure 14. Total Harmonic Distortion, Test Set-Up

MC74HC4066A

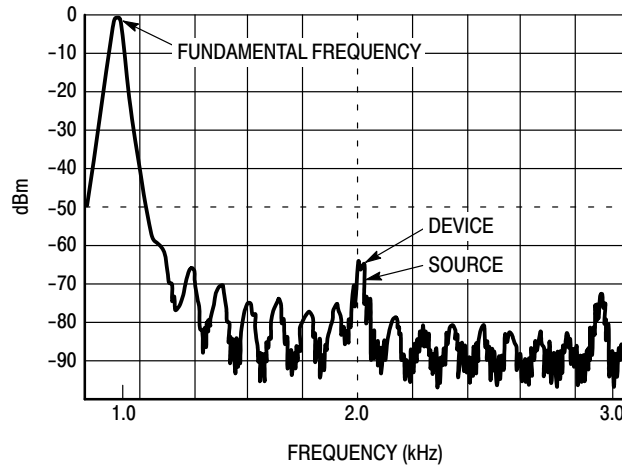

Figure 15. Plot, Harmonic Distortion

APPLICATION INFORMATION

The ON/OFF Control pins should be at V_{CC} or GND logic levels, V_{CC} being recognized as logic high and GND being recognized as a logic low. Unused analog inputs/outputs may be left floating (not connected). However, it is advisable to tie unused analog inputs and outputs to V_{CC} or GND through a low value resistor. This minimizes crosstalk and feedthrough noise that may be picked-up by the unused I/O pins.

The maximum analog voltage swings are determined by the supply voltages V_{CC} and GND. The positive peak analog voltage should not exceed V_{CC} . Similarly, the negative peak analog voltage should not go below GND. In the example

below, the difference between V_{CC} and GND is twelve volts. Therefore, using the configuration in Figure 16, a maximum analog signal of twelve volts peak-to-peak can be controlled.

When voltage transients above V_{CC} and/or below GND are anticipated on the analog channels, external diodes (D_x) are recommended as shown in Figure 17. These diodes should be small signal, fast turn-on types able to absorb the maximum anticipated current surges during clipping. An alternate method would be to replace the D_x diodes with Mosorbs (Mosorb™ is an acronym for high current surge protectors). Mosorbs are fast turn-on devices ideally suited for precise DC protection with no inherent wear out mechanism.

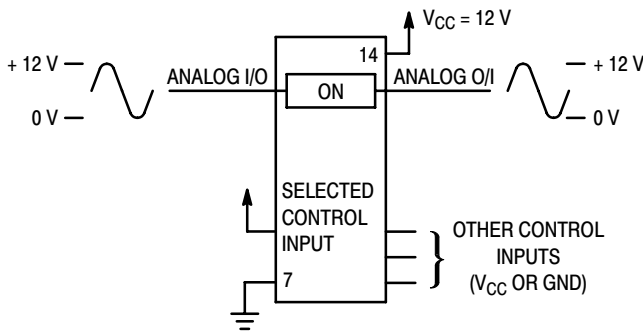

Figure 16. 12 V Application

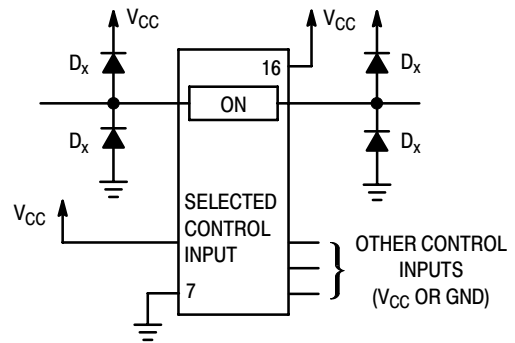

Figure 17. Transient Suppressor Application

MC74HC4066A

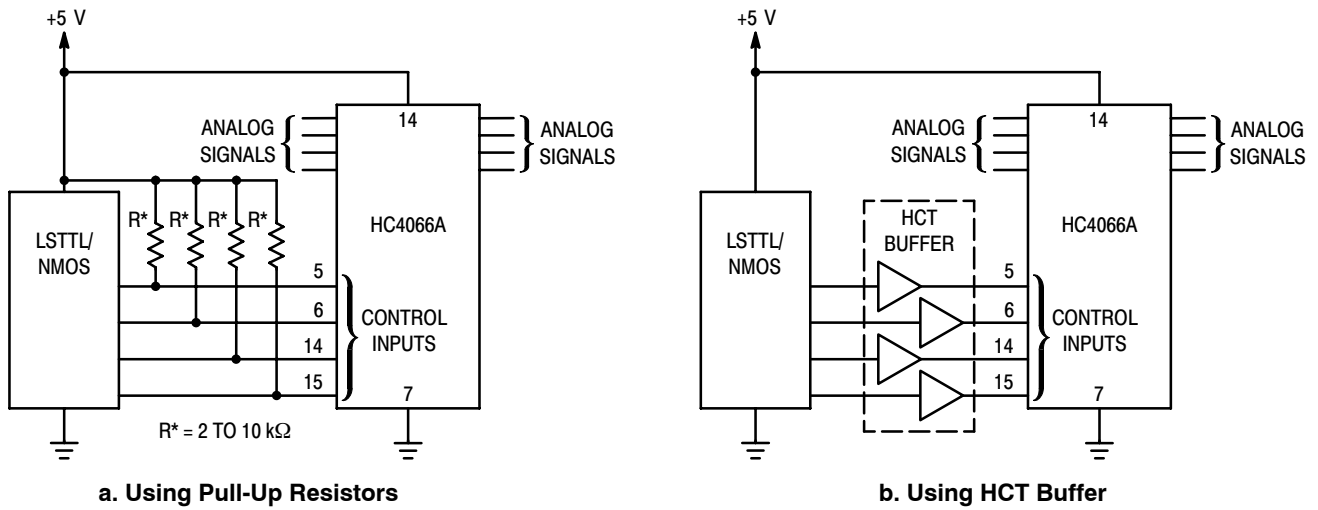

Figure 18. LSTTL/NMOS to HCMOS Interface

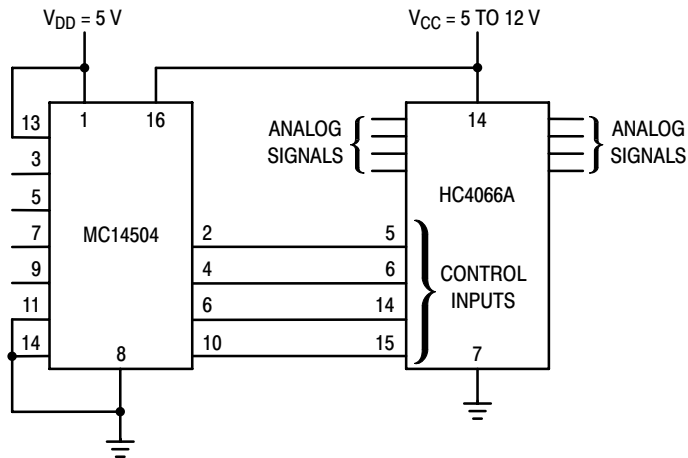

Figure 19. TTL/NMOS-to-CMOS Level Converter
Analog Signal Peak-to-Peak Greater than 5 V
(Also see HC4316A)

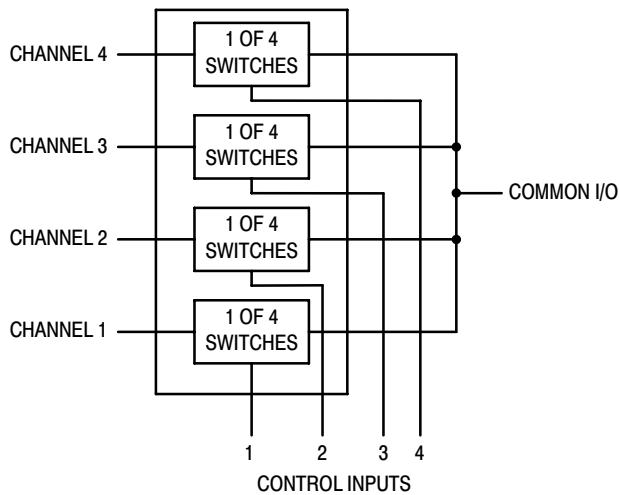

Figure 20. 4-Input Multiplexer

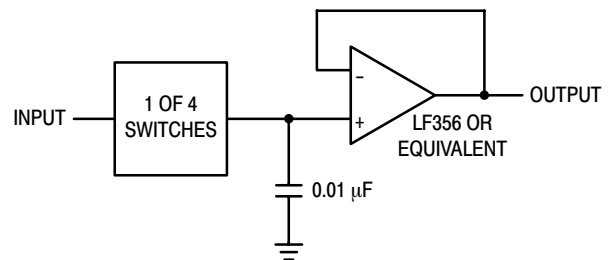
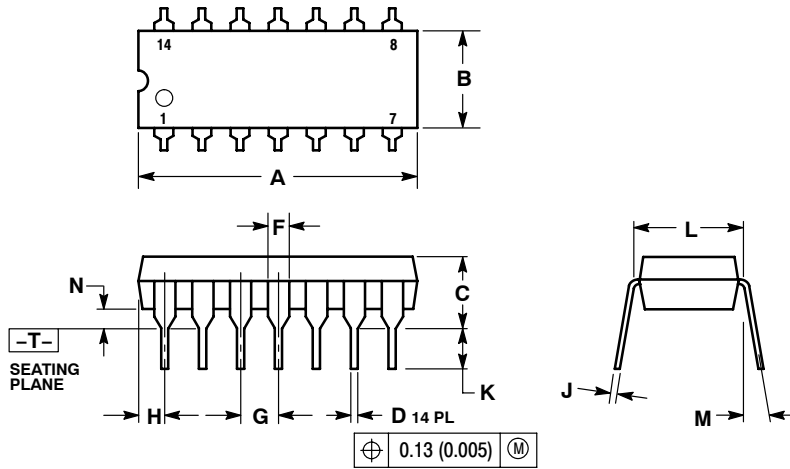

Figure 21. Sample/Hold Amplifier

MC74HC4066A

PACKAGE DIMENSIONS

PDIP-14
CASE 646-06
ISSUE P



NOTES:

1. DIMENSIONING AND TOLERANCING PER ANSI Y14.5M, 1982.
2. CONTROLLING DIMENSION: INCH.
3. DIMENSION L TO CENTER OF LEADS WHEN FORMED PARALLEL.
4. DIMENSION B DOES NOT INCLUDE MOLD FLASH.
5. ROUNDED CORNERS OPTIONAL.

DIM	INCHES		MILLIMETERS	
	MIN	MAX	MIN	MAX
A	0.715	0.770	18.16	19.56
B	0.240	0.260	6.10	6.60
C	0.145	0.185	3.69	4.69
D	0.015	0.021	0.38	0.53
F	0.040	0.070	1.02	1.78
G	0.100 BSC		2.54 BSC	
H	0.052	0.095	1.32	2.41
J	0.008	0.015	0.20	0.38
K	0.115	0.135	2.92	3.43
L	0.290	0.310	7.37	7.87
M	---	10°	---	10°
N	0.015	0.039	0.38	1.01

MC74HC4066A

PACKAGE DIMENSIONS

SOIC-14
CASE 751A-03
ISSUE H

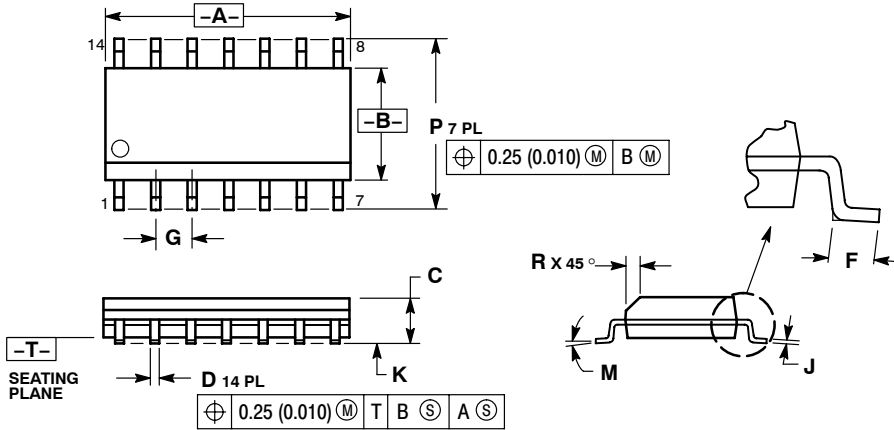

NOTES:

1. DIMENSIONING AND TOLERANCING PER ANSI Y14.5M, 1982.
2. CONTROLLING DIMENSION: MILLIMETER.
3. DIMENSIONS A AND B DO NOT INCLUDE MOLD PROTRUSION.
4. MAXIMUM MOLD PROTRUSION 0.15 (0.006) PER SIDE.
5. DIMENSION D DOES NOT INCLUDE DAMBAR PROTRUSION. ALLOWABLE DAMBAR PROTRUSION SHALL BE 0.127 (0.005) TOTAL IN EXCESS OF THE D DIMENSION AT MAXIMUM MATERIAL CONDITION.

DIM	MILLIMETERS		INCHES	
	MIN	MAX	MIN	MAX
A	8.55	8.75	0.337	0.344
B	3.80	4.00	0.150	0.157
C	1.35	1.75	0.054	0.068
D	0.35	0.49	0.014	0.019
F	0.40	1.25	0.016	0.049
G	1.27 BSC		0.050 BSC	
J	0.19	0.25	0.008	0.009
K	0.10	0.25	0.004	0.009
M	0°	7°	0°	7°
P	5.80	6.20	0.228	0.244
R	0.25	0.50	0.010	0.019

SOLDERING FOOTPRINT*

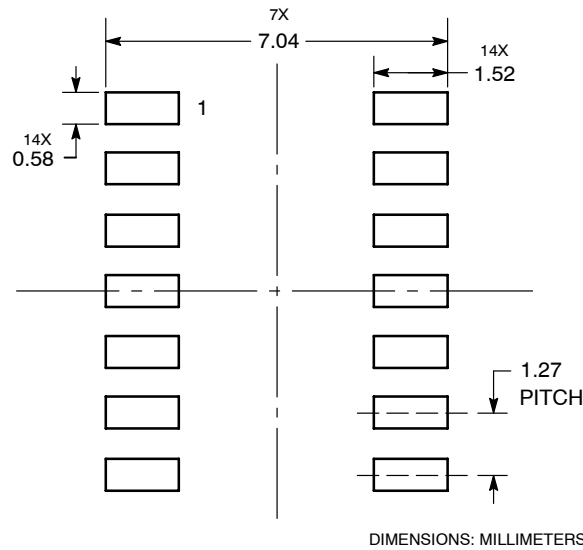

DIMENSIONS: MILLIMETERS

*For additional information on our Pb-Free strategy and soldering details, please download the ON Semiconductor Soldering and Mounting Techniques Reference Manual, SOLDERRM/D.

MC74HC4066A

PACKAGE DIMENSIONS

TSSOP-14
CASE 948G-01
ISSUE B

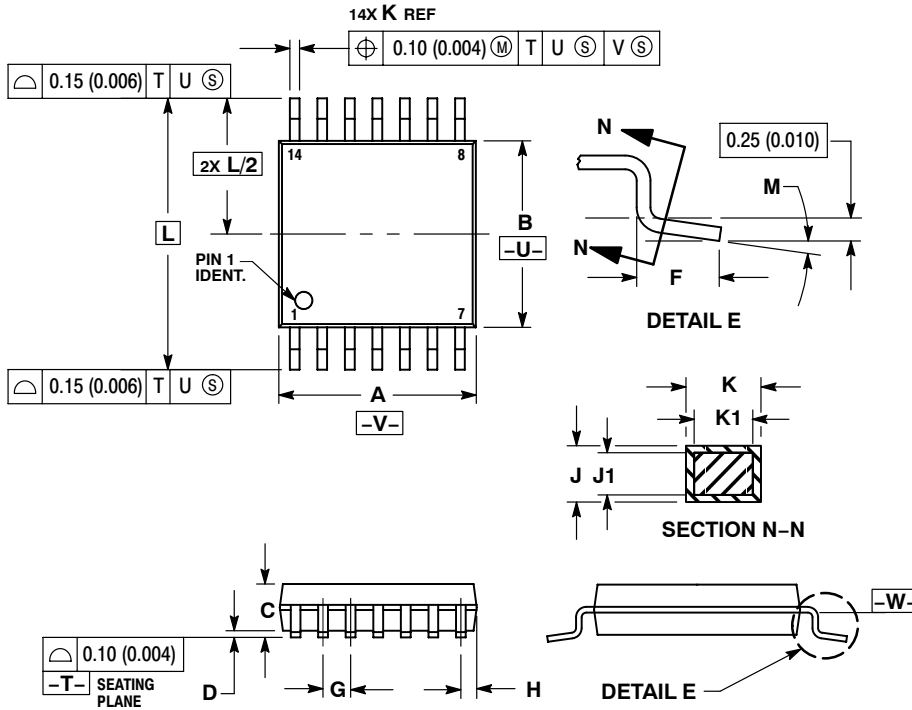

- NOTES:
1. DIMENSIONING AND TOLERANCING PER ANSI Y14.5M, 1982.
 2. CONTROLLING DIMENSION: MILLIMETER.
 3. DIMENSION A DOES NOT INCLUDE MOLD FLASH, PROTRUSIONS OR GATE BURRS. MOLD FLASH OR GATE BURRS SHALL NOT EXCEED 0.15 (0.006) PER SIDE.
 4. DIMENSION B DOES NOT INCLUDE INTERLEAD FLASH OR PROTRUSION. INTERLEAD FLASH OR PROTRUSION SHALL NOT EXCEED 0.25 (0.010) PER SIDE.
 5. DIMENSION K DOES NOT INCLUDE DAMBAR PROTRUSION. ALLOWABLE DAMBAR PROTRUSION SHALL BE 0.08 (0.003) TOTAL IN EXCESS OF THE K DIMENSION AT MAXIMUM MATERIAL CONDITION.
 6. TERMINAL NUMBERS ARE SHOWN FOR REFERENCE ONLY.
 7. DIMENSION A AND B ARE TO BE DETERMINED AT DATUM PLANE -W-

DIM	MILLIMETERS		INCHES	
	MIN	MAX	MIN	MAX
A	4.90	5.10	0.193	0.200
B	4.30	4.50	0.169	0.177
C	---	1.20	---	0.047
D	0.05	0.15	0.002	0.006
F	0.50	0.75	0.020	0.030
G	0.65 BSC		0.026 BSC	
H	0.50	0.60	0.020	0.024
J	0.09	0.20	0.004	0.008
J1	0.09	0.16	0.004	0.006
K	0.19	0.30	0.007	0.012
K1	0.19	0.25	0.007	0.010
L	6.40 BSC		0.252 BSC	
M	0°	8°	0°	8°

SOLDERING FOOTPRINT*

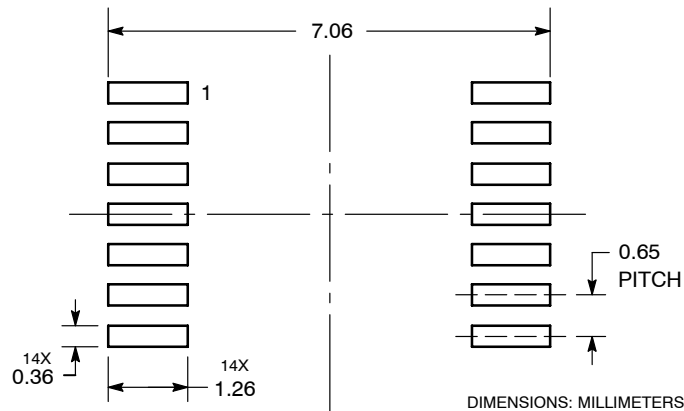

*For additional information on our Pb-Free strategy and soldering details, please download the ON Semiconductor Soldering and Mounting Techniques Reference Manual, SOLDERRM/D.

MC74HC4066A

PACKAGE DIMENSIONS

SOEIAJ-14
CASE 965-01
ISSUE A

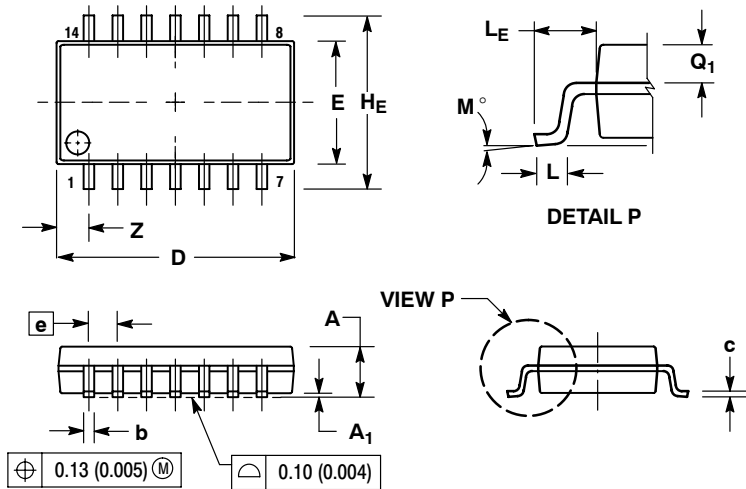

NOTES:

1. DIMENSIONING AND TOLERANCING PER ANSI Y14.5M, 1982.
2. CONTROLLING DIMENSION: MILLIMETER.
3. DIMENSIONS D AND E DO NOT INCLUDE MOLD FLASH OR PROTRUSIONS AND ARE MEASURED AT THE PARTING LINE. MOLD FLASH OR PROTRUSIONS SHALL NOT EXCEED 0.15 (0.006) PER SIDE.
4. TERMINAL NUMBERS ARE SHOWN FOR REFERENCE ONLY.
5. THE LEAD WIDTH DIMENSION (b) DOES NOT INCLUDE DAMBAR PROTRUSION. ALLOWABLE DAMBAR PROTRUSION SHALL BE 0.08 (0.003) TOTAL IN EXCESS OF THE LEAD WIDTH DIMENSION AT MAXIMUM MATERIAL CONDITION. DAMBAR CANNOT BE LOCATED ON THE LOWER RADIUS OR THE FOOT. MINIMUM SPACE BETWEEN PROTRUSIONS AND ADJACENT LEAD TO BE 0.46 (0.018).

DIM	MILLIMETERS		INCHES	
	MIN	MAX	MIN	MAX
A	---	2.05	---	0.081
A ₁	0.05	0.20	0.002	0.008
b	0.35	0.50	0.014	0.020
c	0.10	0.20	0.004	0.008
D	9.90	10.50	0.390	0.413
E	5.10	5.45	0.201	0.215
e	1.27 BSC		0.050 BSC	
H _E	7.40	8.20	0.291	0.323
0.50	0.50	0.85	0.020	0.033
L _E	1.10	1.50	0.043	0.059
M	0°	10°	0°	10°
Q ₁	0.70	0.90	0.028	0.035
Z	---	1.42	---	0.056

ON Semiconductor and are registered trademarks of Semiconductor Components Industries, LLC (SCILLC). SCILLC reserves the right to make changes without further notice to any products herein. SCILLC makes no warranty, representation or guarantee regarding the suitability of its products for any particular purpose, nor does SCILLC assume any liability arising out of the application or use of any product or circuit, and specifically disclaims any and all liability, including without limitation special, consequential or incidental damages. "Typical" parameters which may be provided in SCILLC data sheets and/or specifications can and do vary in different applications and actual performance may vary over time. All operating parameters, including "Typicals" must be validated for each customer application by customer's technical experts. SCILLC does not convey any license under its patent rights nor the rights of others. SCILLC products are not designed, intended, or authorized for use as components in systems intended for surgical implant into the body, or other applications intended to support or sustain life, or for any other application in which the failure of the SCILLC product could create a situation where personal injury or death may occur. Should Buyer purchase or use SCILLC products for any such unintended or unauthorized application, Buyer shall indemnify and hold SCILLC and its officers, employees, subsidiaries, affiliates, and distributors harmless against all claims, costs, damages, and expenses, and reasonable attorney fees arising out of, directly or indirectly, any claim of personal injury or death associated with such unintended or unauthorized use, even if such claim alleges that SCILLC was negligent regarding the design or manufacture of the part. SCILLC is an Equal Opportunity/Affirmative Action Employer. This literature is subject to all applicable copyright laws and is not for resale in any manner.

PUBLICATION ORDERING INFORMATION

LITERATURE FULFILLMENT:
Literature Distribution Center for ON Semiconductor
P.O. Box 5163, Denver, Colorado 80217 USA
Phone: 303-675-2175 or 800-344-3860 Toll Free USA/Canada
Fax: 303-675-2176 or 800-344-3867 Toll Free USA/Canada
Email: orderlit@onsemi.com

N. American Technical Support: 800-282-9855 Toll Free
USA/Canada
Europe, Middle East and Africa Technical Support:
Phone: 421 33 790 2910
Japan Customer Focus Center
Phone: 81-3-5773-3850

ON Semiconductor Website: www.onsemi.com
Order Literature: <http://www.onsemi.com/orderlit>
For additional information, please contact your local Sales Representative